

PowerTech™

4045AFM85 Diesel Engine

Marine Propulsion Engine Specifications



4045AFM85 shown

Dimensions

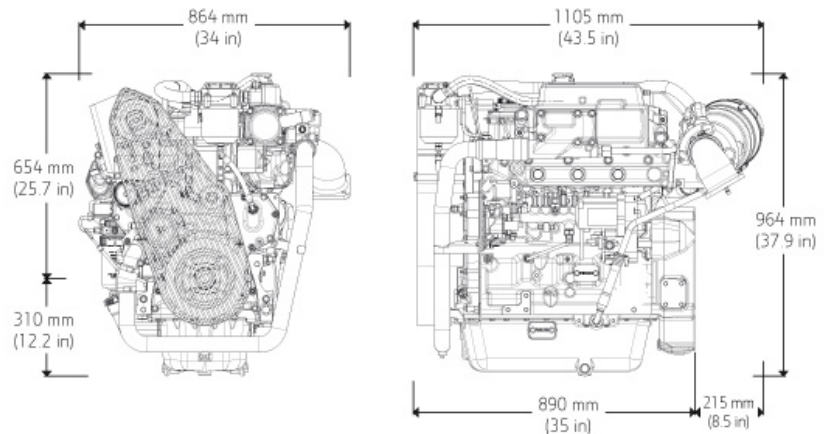

Dimensions shown in mm (in) may vary according to options selected. Contact your distributor for more information.

Emissions

EPA Commercial Marine Tier 3

IMO MARPOL Annex VI Tier II Compliant

General Data (Based on Standard Option Configuration)

Model	4045AFM85	Length maximum - mm (in)	1105 (43.5)
Number of cylinders	4	Length to rear face of flywheel housing - mm (in)	890 (35.0)
Displacement - L (cu in)	4.5 (275)	Flywheel housing SAE	3
Bore and Stroke-- mm (in)	107 x 127 (4.21 x 5.00)	Height - mm (in)	964 (37.9)
Engine Type	In-line, 4- Cycle	Height, crankshaft centerline to top - mm (in)	654 (25.7)
Aspiration	Turbocharged and air-to-coolant aftercooled	Height, crankshaft centerline to bottom - mm (in)	310 (12.2)
		Weight, dry - kg (lb)	578 (1274)

Classification Societies

ABS, BV, CCS, CRS, DNV-GL, LR

*SOLAS and other accessories available. Contact your distributor for details.

Engine Specifications

Performance ratings	Power kW (bhp)	Rated Speed (rpm)	Rated fuel consumption L/hr (gal/hr)
M1	119 (160)	2300	33.2 (8.8)
M2	134 (180)	2400	36.9 (9.7)
M3	149 (200)	2500	44.2 (11.7)
M4	168 (225)	2600	48.6 (12.8)

Metric hp = Brake hp x 1.01387

M rating	M1	M2	M3	M4
Typical load factor	> 65%	< =65%	< =50%	< =40%
Typical annual usage (hr)	Unrestricted	3,000-5,000 hr	2,000-4,000 hr	1,000-3,000 hr
Typical full-power operation (hr)	Uninterrupted	16 of each 24 hr	4 of each 12 hr	1 of each 12 hr

Ratings are based on ISO 8655 standard power rating and the SAE J1 228 cranks haft power rating.

Flexibility of installation due to range of options.

See your John Deere Power Systems engine distributor or marine dealer for more detailed performance information.

Features and Benefits

High Torque and Low Rated RPM

- High torque provides excellent vessel control and maneuverability. Lower rated propulsion RPM reduces vibration and noise for improved crew comfort.

4-Valve Cylinder Head

- Excellent airflow through 4-valve cylinder head delivers greater low-speed torque and better transient response time.

High-pressure Common-rail (HPCR)

- The HPCR fuel system provides variable common-rail pressure, multiple injections, and higher injection pressures. It also controls fuel injection timing and provides precise control for the start, duration, and end of injection. Electronic transfer pump is self-priming for ease of maintenance. Provides high performance, excellent fuel economy, and low emissions.

Water-cooled Exhaust Manifold

- Integrated components eliminate external hoses and fittings that can leak or break. Wet exhaust manifold creates a cooler and quieter environment for passengers and crew.

Replaceable Cylinder Liners

- Replaceable wet-type cylinder liners are precision-machined and hardened for long life. Allows engine to be rebuilt to original specifications.

Electronic Engine Control Unit (ECU)

- Advanced fault code diagnostics and customizable engine protections ensure reliability and uptime. Provides highly customizable features and trim to integrate your vessel.

Integrated Heat Exchanger

- Integrated expansion tank, heat exchanger, and exhaust manifold reduce the chance of leaks. High-capacity heat exchanger provides reliable operation in adverse conditions.

Keel-cooled or Heat Exchanger

- Closed cooling system in keel-cooled engine option eliminates the need for a sea strainer, seawater pump, or anodes. Heat exchanger option offers a lighter, more compact, and simpler engine installation.

Internal Balancers

- Internal balancers reduce engine noise and vibration for crew comfort. NOTE: John Deere 4045 engines only.

Multiple Service Options

- Either-side oil fill/dipstick combinations and remote oil and fuel filter options are available for easier service access.