

E-SERIES SKID STEER LOADERS

318E/320E/326E/328E/332E



JOHN DEERE



Your words carry a lot of weight, too.

When our customers express their opinions, we listen. And you'll discover plenty of bright ideas in our E-Series Skid Steers that are the result of your input. Such as courtesy lighting for illuminated cab entrance/exit in dark environments. Larger-displacement slower-running diesels for easier cold-weather starting and improved fuel efficiency. Significantly more power in the top-of-the-line 332E. Increased performance in the 328E. Best-in-class visibility and bucket breakout forces in all five models. And increased operating capacities in the 318E, 320E, and 326E. You have more control choices, too, including exclusive switchable electrohydraulic (EH) H-ISO-foot controls. And quieter, more spacious operator stations. Other customer-inspired enhancements include a redesigned rear hood and easier-to-remove/replace heavier-duty engine side shields that simplify servicing. You won't find a more owner- and operator-friendly skid steer on the market. You have our word on it.

Specifications	318E	320E	326E	328E	332E
Power	47.1 kW (63 gross hp) / 44.8 kW (60 net hp)	51.7 kW (69 gross hp) / 49.4 kW (66 net hp)	54.8 kW (74 gross hp) / 52.5 kW (70 net hp)	64.0 kW (86 gross hp) / 62.0 kW (83 net hp)	74.6 kW (100 gross hp) / 72.0 kW (97 net hp)
Rated Operating Capacity	885 kg (1,950 lb.)	994 kg (2,190 lb.)	1221 kg (2,690 lb.)	1271 kg (2,800 lb.)	1453 kg (3,200 lb.)
Breakout Force					
Boom	1589 kg (3,500 lb.)	1589 kg (3,500 lb.)	2270 kg (5,000 lb.)	2270 kg (5,000 lb.)	2996 kg (6,600 lb.)
Bucket	2724 kg (6,000 lb.)	2724 kg (6,000 lb.)	3519 kg (7,750 lb.)	4676 kg (10,300 lb.)	6299 kg (13,875 lb.)
Tipping Load	1771 kg (3,900 lb.)	1989 kg (4,380 lb.)	2443 kg (5,380 lb.)	2542 kg (5,600 lb.)	2906 kg (6,400 lb.)



DEERE 320E

RE



1. Although not exactly a sunroof, the bolt-on top window on cab-equipped models removes quickly for increased ventilation and/or easy cleaning.

2. Standard courtesy lighting stays on up to 90 seconds after the engine is shut down, illuminating the way for easier exits out of dark barns or off after-hour jobsites.



Open the door to a more productive day.

When was the first time that “compact” and “comfortable” were accurately used together to describe a skid steer? But with the many refinements found in our E-Series, we can make the claim with a straight face. Wide-open entryways and flat floors allow easier in and out, and provide more foot- and legroom. Operators will also like what they see from the sculped suspension seat. All-around visibility is expansive and second-to-none. The highly efficient HVAC system employs eight automotive-style vents to keep the glass clear and cab comfortable. Plus plenty of other cab amenities including an optional AM/FM weather-band radio with dual speakers help tune-in more productivity.

Triple-interlock operator-presence system automatically applies the brakes when the lap bar is raised, the operator leaves the seat, or the engine is shut down.

Expansive curved front glass, large top window, and low side windows make it easy to see the surrounding jobsite. Even with an expanded engine compartment, best-in-class sightlines provide a clear view of the action behind you, as well.

Flat floors in the 326E, 328E, and 332E provide 33-percent-more comfort-lending foot room. Make getting in and out of the cab easier, too.

Fully adjustable pull-down padded lap bar provides comfortable arm support.

HVAC system employs eight automotive-style louvers to direct warm or cold airflow where it's appreciated most — on the operator. For production-boosting year-round comfort.

Cabs and floors are tightly sealed and pressurized to keep out dust and noise.

We've got your back with a sculped air-ride or mechanical-suspension seat to help smooth the ride. Choose either a cloth or vinyl air-suspension seat in cab-equipped models.

Storage box, cup holder, and iPod™/cell-phone holder (with nearby 12-volt power port) provide plenty of room to stow your stuff.





Set your sites on getting more done.

Want a skid steer that's more productive? Get one of ours. Optimal weight distribution, low center of gravity, high ground clearance, and long wheelbase deliver superior stability. But getting there is only half the battle. These skid steers also excel at putting material in its place. Their patented vertical-lift boom rises to the occasion, delivering exceptional lift height and reach. So you can do more, with less effort.

1. Superior axle torque and impressive bucket breakout deliver the leverage and traction to dig in where others just spin. For best-in-class pushing, prying, and digging power.
2. Optional ride control's shock-absorbing boom cylinders cushion bumps, helping retain full bucket loads all the way to your destination. Help speed navigation over rough terrain, too.

3. Impressive tipping load and rated operating capacities empower our E-Series Skid Steers to master an ever-changing variety of material-handling tasks.
4. Some jobs can be a real stretch. Our patented boom design clears high sideboards and even dumps to the center of tandem-axle trucks.



These are our most powerful skid steers ever. Larger field-proven ultra-reliable diesels deliver more displacement and significantly more torque rise and usable power, while meeting EPA Interim Tier 4 (IT4)/EU Stage IIIB and Final Tier 4 (FT4)/Stage IV regulations.

E-Series' unequalled ability comes from a design that optimizes hydraulics, lift capabilities, and pushing forces.

Fully electronic injection systems aid cold-weather starting and enable E-Series engines to run at lower rpm without sacrificing power. For longer life and better fuel efficiency.

Fast ground speeds and large bucket capacities enable these nimble material movers to make the most of every cycle. Need even more speed? Opt for a two-speed transmission.



1

2

3

4

Become a “controls freak.”

We'll excuse you for becoming a bit of a “controls freak” after running one of our skid steers. Offering one-of-a-kind options, only the E-Series lets an operator decide how the work gets done. ISO, H-pattern, or foot/joystick electrohydraulic (EH) controls are all available. Or, choose our exclusive switchable EH option that lets you select any of the above, at any time, at the push of a button. That's just for starters. Add the EH Joystick Performance Package, and you can customize vehicle and attachment response. The ultimate people pleasers, our E-Series truly is all things to all operators.



1. Overhead panel conveniently places machine info on the left, control switches to the right. Easy-to-read LCD monitor accesses a wealth of machine info and control — including vital operating conditions and advanced diagnostics.
2. Joystick buttons, rotary switch, and triggers actuate and control the auxiliary hydraulics/flow rates, boom float, and two-speed transmission.
3. Optional keyless-start sealed-switch panel includes an anti-theft system with one owner and five individual codes. And simple fingertip control of numerous options.





EH joysticks are standard on the 328E and 332E; optional on the 318E, 320E, and 326E. They're our smoothest and most responsive yet, providing enhanced control and operating ease.

Now you can have your joysticks and foot pedals, too. Exclusive switchable EH controls allow the operator to choose ISO, H-pattern, or EH joystick and foot controls. Simply press a button on the keyless sealed-switch module (SSM).

Want to make the most of our vertical-lift boom design? Add the self-level option and simplify your material-handling tasks.

EH Joystick Performance Package lets an operator customize operation and response to personal preferences through the SSM:

- **Attachment control** operates hydraulic-powered additions such as augers or breakers.
- **Creep control** allows slow incremental travel speeds while maintaining full engine and hydraulic power. It's ideal for work with cold planers or trenchers.
- **Boom and bucket speed settings** enable precision (slow), utility (normal), and productivity (fast) responses.
- **Switchable controls** let you choose ISO or H-pattern.
- **Propel aggressiveness** modes set travel/steering response rates. **Precision** is ideal for work in tight spaces. **Utility** is for normal operation. **Production** delivers faster response for stockpiling and truck loading.



Work our connections, as you expand yours.

If you're looking to broaden your business, your John Deere dealership is the place to start. Their equipment offering includes more than 100 Worksite Pro™ attachments that will help expand your efforts. E-Series Skid Steers are designed with these additions in mind. The universal Quik-Tatch™ makes attachment switchover quick and easy. Standard-flow auxiliary hydraulics with connect-under-pressure couplers is also standard. And if your equipment yard includes our compact track loaders, compact excavators, or compact loaders, many of these attachments are interchangeable between machines. Talk to your dealer to learn more.

Numerous rock, multipurpose, construction, utility, and tooth buckets are available in varying widths and capacities.

Clear heavy brush and saplings with our rotary cutters. Or put a mulching head to work shredding trees and stumps.

High- or standard-flow trenchers and removable backhoes work well for irrigation and underground utility tasks.

Cleanup is quicker with tools such as our brush, scrap, and utility grapples. Two hydraulic-actuated dual-action tongs provide superior material retention.

Worksite Pro attachments:

- Ag forks
- Augers
- Backhoes
- Bale spears (round, square)
- Blades (snow, utility)
- Breakers/hammers
- Brooms (angle, pickup)
- Cold planers
- Dozer blades
- Grapples (ag utility, brush-tined, scrap)
- Landplanes
- Mulching heads
- Multipurpose buckets
- Pallet forks
- Power rakes
- Rock buckets
- Roller levels
- Rotary cutters
- Rotary tillers
- Scrapers (material, manure)
- Side-discharge buckets
- Snow blowers
- Snow pushers
- Trenchers
- Vibratory rollers





1. Our skid steers are also your foul-weather friends. Equipped with snow blower, snow pusher, blade, or angle broom, they make quick work of cleaning up whatever drops your way.
2. Bust through with any of our four breakers. Their low-pressure nitrogen-charged design cushions both machine and operator.
3. Perfect for concrete or asphalt flatwork — our angle brooms, rollers, cold planers, and wide variety of buckets let you hit the road running.
4. Our offering of landscape and nursery tools continues to grow and includes rotary tillers, augers, pallet forks, power rakes, landplanes, dozer blades, and roller levels, to list just a few.
5. For handling feed, cleaning out pens, re-bedding stalls, or numerous other chores — we've got the utility grapples, manure scrapers, forks, bale spears, and buckets to get it done.

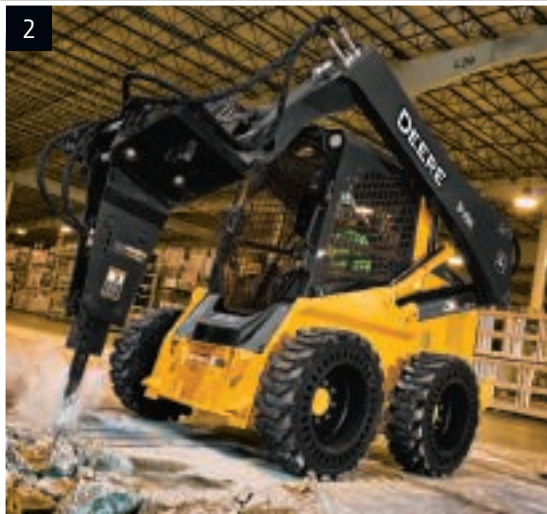

Nothing runs like a Deere, because nothing is built like one.

Downtime and deadlines don't mix — which is why we build our skid steers the way we do. Large-displacement electronic-injection diesels headline the list of uptime-boosting enhancements. Other job-proven durability difference-makers include our exclusive V-plenum cooling system with hydraulically driven variable-speed fans. Heavy-duty axles. Beefy booms and upper links. And integrated rear bumpers. When you know how they're built, you'll run a Deere.

Large cross-section boom arms and heavy-duty upper links deliver the strength to endure tough tasks for long-term durability.

The E-Series employs the same job-proven EPA Interim Tier 4 (IT4)/EU Stage IIIB and Final Tier 4 (FT4)/Stage IV technologies as our larger equipment. Simple, fully integrated, and fully supported, our emission solution delivers industry-leading fuel efficiency and uptime.

Diesel particulate filter (DPF) cleaning doesn't impact or interrupt machine performance under normal operating conditions.

Switches and electrical connectors are sealed from moisture and dirt to help prevent corrosion.

Spring-applied, hydraulic-released wet-disc park brakes are fully enclosed and never require adjustment.

O-ring face-seal hydraulic fittings virtually eliminate aggravating and costly oil leaks.

Auto-idle helps preserve engine life and conserve fuel, reducing engine speed after the operator has vacated the seat. Full auto-idle (available with EH controls) slows the engine after five seconds of inactivity and resumes preset engine speed with any joystick movement.

Auto-shutdown system monitors engine and hydraulic vitals, and issues an audible warning when limits are exceeded. If necessary, it shuts down the machine to help prevent damage.

318E/320E's auxiliary hydraulic lines are routed through the boom arms for an extra degree of protection. Couplers connect under pressure for quick and easy powered-attachment hookup.

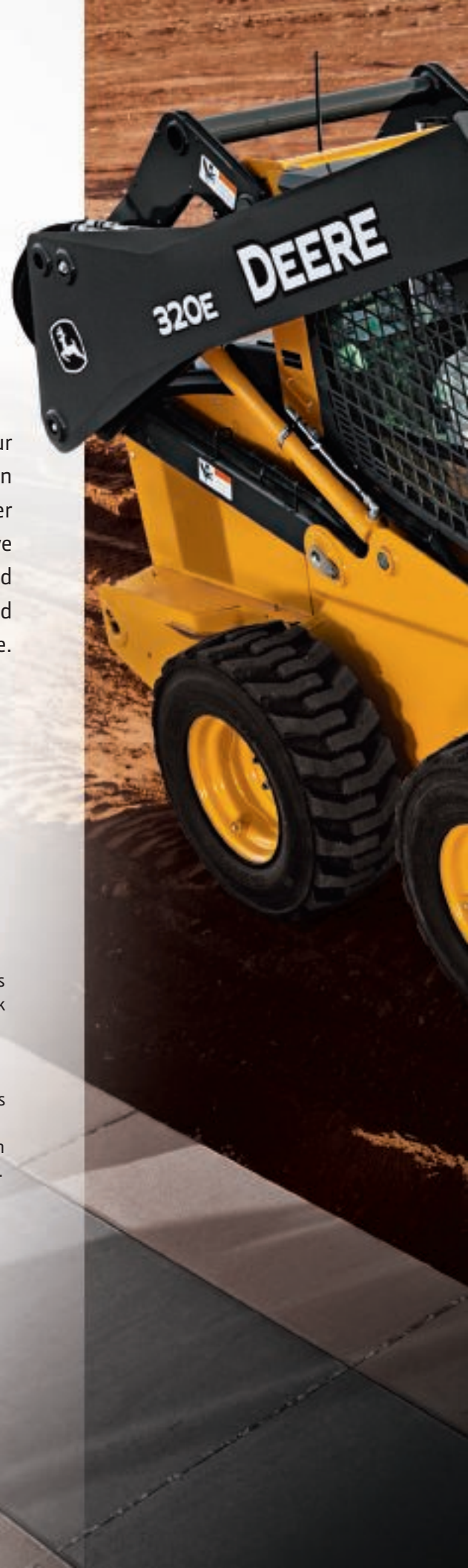



1. Industry-exclusive design separates coolers in an innovative V-shape configuration that's 10-percent-more efficient. Large aluminum hydraulic cooler and radiator provide the necessary capacity for high-ambient-temperature operation.
2. Hydraulic-driven variable-speed fan runs only as fast or frequently as needed — for improved power and fuel efficiency, and decreased noise and debris flow through the coolers. Exclusive reversible option can be set to automatically reverse as often as the application dictates to clear core-clogging buildup.
3. Rear bumper with integral tie-downs protects cooling components from run-ins with obstacles. Add the optional heavy-duty rear grille for even more durability.

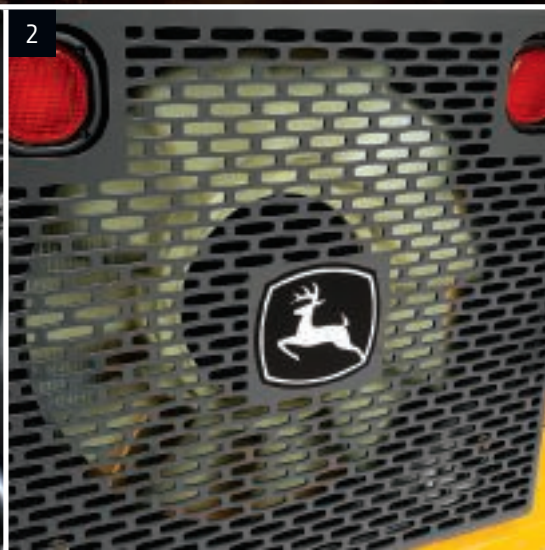

Maintenance made “E”asy.

Servicing an E-Series Skid Steer is quick and easy. So easy, in fact, that you won't even have to raise its boom for daily service or most periodic maintenance. Checkpoints are conveniently grouped and easily reached beneath the hinged hood. And removable side panels give way to the coolers, maintenance-free battery, and fluid and air filters. If necessary, the operator station tilts in minutes for best-in-class drivetrain access. And industry-leading parts and service are just as accessible at more than 1,300 John Deere dealer locations from coast to coast.



Daily servicing is quick and convenient. Simply lift the gas-shock-supported hood for ground-level access to check fluids and refuel.

Removable rear side panels allow wide-open service access and are easier to remove and replace. Stronger, too.

Through-the-monitor onboard diagnostics help speed troubleshooting.

These skid steers share components such as engines with our CTLs and compact excavators, making it easier to ensure you always have the right filters and fluids on hand.

Fluid-fill and service checkpoints are grouped and color-coded. And a conveniently displayed maintenance chart helps ensure that nothing gets overlooked.

Diesel particulate filter (DPF) service interval is 3,000 hours, and can be done by your John Deere dealer.

V-plenum cooling-system design resists debris buildup and makes radiator and cooler cores easier to clean.

Because no maintenance beats low maintenance, engine serpentine belts never need adjustment.

Compare the cost of parts and labor for recommended maintenance with other makes. The E-Series will save you significant money.

1. Getting to the heart of a Deere is easy. There's no need to raise the boom — just pivot the cab and remove the floor. Takes only minutes.
2. Need extra elbowroom? Raise the boom and remove the side shields for wide-open engine-compartment access. Unique lock lever secures the boom from inside the cab.
3. Spin-on filters and environmental drains allow quick fluid changes.
4. Hydraulic sight gauge and see-through coolant and windshield washer fluid reservoirs let you check levels at a glance.

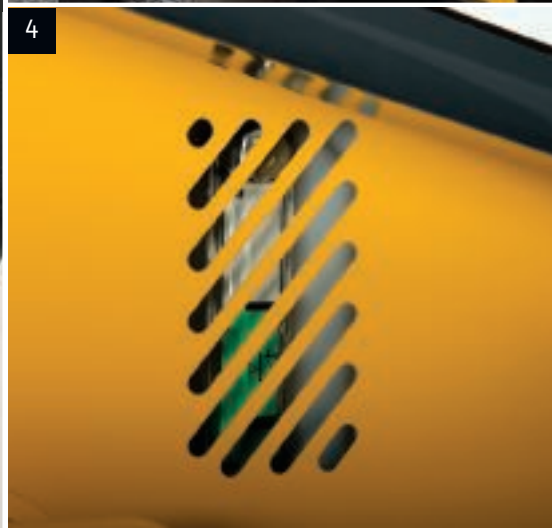

318E / 320E



Engine	318E	320E
Manufacturer and Model	Yanmar 4TNV98C (optional 4TNV98CT)	Yanmar 4TNV98C (optional 4TNV98CT)
Non-Road Emission Standards	EPA Final Tier 4/EU Stage IV	EPA Final Tier 4/EU Stage IV
Cylinders	4	4
Net Peak Power (SAE J1349 / ISO 9249)	44.8 kW (60 hp) at 2,500 rpm	49.4 kW (66 hp) at 2,500 rpm
Gross Rated Power (ISO 14396)	47.1 kW (63 hp) at 2,500 rpm	51.7 kW (69 hp) at 2,500 rpm
Peak Torque	241 Nm (178 ft.-lb.) at 1,625 rpm	241 Nm (178 ft.-lb.) at 1,625 rpm
Displacement	3.3 L (203 cu. in.)	3.3 L (203 cu. in.)
Rated Engine Speed	2,500 rpm	2,500 rpm
Torque Rise	34% at 1,625 rpm	22% at 1,625 rpm
Aspiration	Naturally aspirated (optional turbocharger)	Naturally aspirated (optional turbocharger)
Air Cleaner	Dry dual element	Dry dual element
Cooling	318E / 320E	
Fan Type	Variable-speed hydraulic drive (optional reversing fan drive)	
Powertrain	318E	320E
Type	Hydrostatic-manual or electrohydraulic controls; 4 – 80 heavy-duty, continuous-loop chains	
Speeds		
Single Speed	11.1 km/h (6.9 mph)	11.1 km/h (6.9 mph)
2 Speed, High	16.3 km/h (10.1 mph)	17.9 km/h (11.1 mph)
Axles	Induction-hardened, one-piece forged axle shafts with maintenance-free oil-bath lubrication of inner and outer axle bearings	
Maximum Axle Torque, Single Speed	6374 Nm (4,701 lb.-ft.)	6771 Nm (4,994 lb.-ft.)
Tractive Effort	3318 kgf (7,728 lbf)	3220 kgf (7,491 lbf)
Final Drive	High-strength, adjustment-free chains	
Brakes	Integral, automatic, spring-applied, hydraulically released, wet-disc park brake	
Hydraulics		
Pump Flow		
Standard	68 L/m (18 gpm)	76 L/m (20 gpm)
Total with High-Flow Option	95 L/m (25 gpm)	106 L/m (28 gpm)
System Pressure at Couplers	22 408 kPa (3,250 psi)	22 408 kPa (3,250 psi)
Hydraulic Horsepower Flow (calculated)		
Standard	25 kW (34 hp)	28 kW (38 hp)
High	35 kW (47 hp)	40 kW (53 hp)
Cylinders	318E / 320E	
Type	John Deere heat-treated, chrome-plated, polished cylinder rods, hardened steel (replaceable bushings) pivot pins	
Electrical		
Voltage	12 volt	
Battery Capacity	750 CCA (optional 925 CCA)	
Alternator Rating	70 amp	
Lights	Halogen, 2 front and 1 rear	
Operator's Station	ROPS (ISO 3471) / FOPS (ISO 3449) structure with quick-pivot standard	
Tires/Wheels	318E	320E
Standard Tire Size	10 x 16.5 8 PR SKS Extra Wall Heavy Duty	12 x 16.5 8 PR SKS Extra Wall
Serviceability	318E / 320E	
Refill Capacity		
Fuel Tank	76 L (20 gal.)	
Operating Weight	318E	320E
Base Machine	3178 kg (7,000 lb.)	3246 kg (7,150 lb.)



Machine Dimensions	318E	320E
A Length without Bucket	2.85 m (112 in.) (9 ft. 4 in.)	2.85 m (112.0 in.) (9 ft. 4 in.)
B Length with Foundry Bucket	3.47 m (136.8 in.) (11 ft. 5 in.)	3.47 m (136.8 in.) (11 ft. 5 in.)
C Width without Bucket	1.61 m (63.3 in.) (5 ft. 3 in.)	1.76 m (69.2 in.) (5 ft. 9 in.)
D Height to Top of ROPS	1.98 m (78.1 in.) (6 ft. 6 in.)	2.02 m (79.4 in.) (6 ft. 7 in.)
E Height to Hinge Pin	3.05 m (120.2 in.) (10 ft. 0 in.)	3.09 m (121.5 in.) (10 ft. 2 in.)
F Dump Height with Foundry Bucket	2.43 m (95.7 in.) (8 ft. 0 in.)	2.46 m (96.9 in.) (8 ft. 1 in.)
G Dump Reach		
With Foundry Bucket	0.78 m (30.7 in.)	0.74 m (29.0 in.)
With Construction Bucket	0.96 m (37.8 in.) (3 ft. 2 in.)	0.92 m (36.3 in.) (3 ft. 0 in.)
H Wheelbase	1.13 m (44.3 in.) (3 ft. 8 in.)	1.13 m (44.3 in.) (3 ft. 8 in.)
I Ground Clearance	0.19 m (7.3 in.)	0.22 m (8.5 in.)
J Angle of Departure	26 deg.	28 deg.
K Front Turn Radius with Foundry Bucket	2.03 m (79.8 in.) (6 ft. 8 in.)	2.03 m (79.8 in.) (6 ft. 8 in.)
L Dump Angle (full lift height)	43 deg.	43 deg.
M Bucket Rollback (ground level)	33 deg.	33 deg.

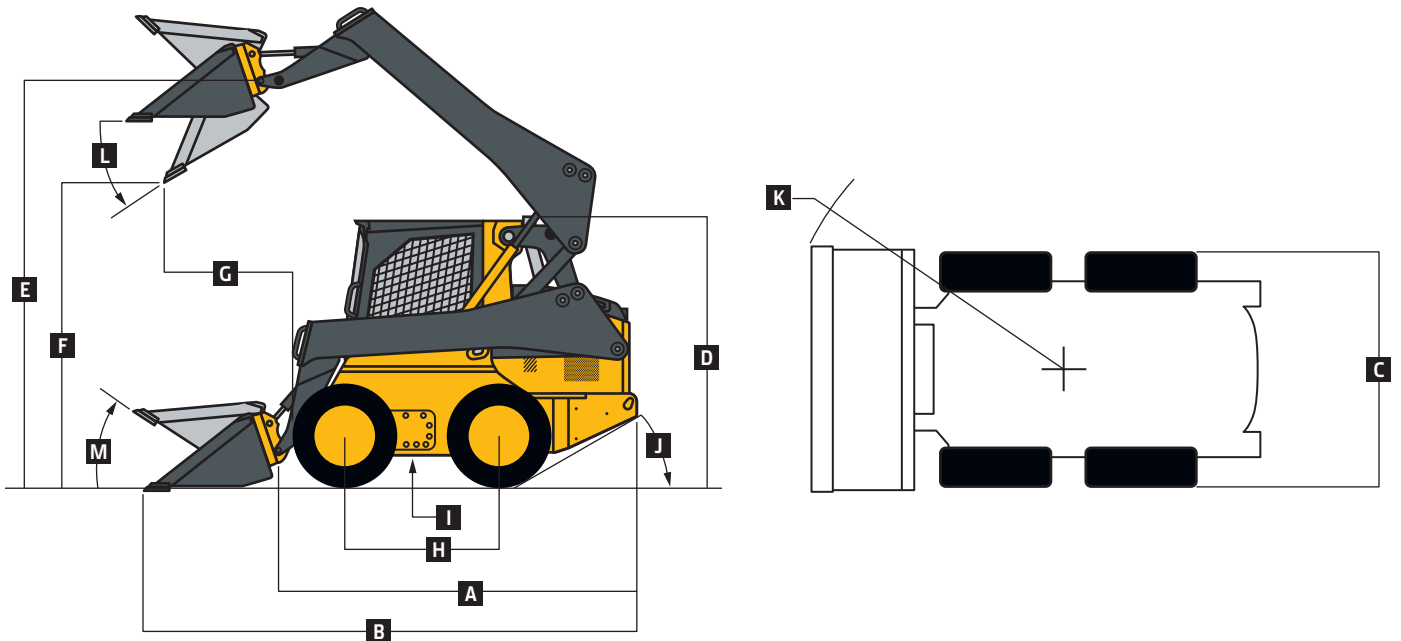

Loader Performance	318E	320E
Tipping Load	1771 kg (3,900 lb.)	1989 kg (4,380 lb.)
SAE Rated Operating Capacity	885 kg (1,950 lb.)	994 kg (2,190 lb.)
With Counterweight	953 kg (2,100 lb.)	1067 kg (2,350 lb.)
Boom Breakout	1589 kg (3,500 lb.)	1589 kg (3,500 lb.)
Bucket Breakout Force	2724 kg (6,000 lb.)	2724 kg (6,000 lb.)

326E / 328E / 332E

Engine	326E	328E	332E
Manufacturer and Model	Yanmar 4TNV98CT	Yanmar 4TNV94CHT	Yanmar 4TNV94CHT
Non-Road Emission Standards	EPA Final Tier 4/EU Stage IV	EPA Interim Tier 4/EU Stage IIIB	EPA Interim Tier 4/EU Stage IIIB
Cylinders	4	4	4
Net Peak Power (SAE J1349 / ISO 9249)	52.5 kW (70 hp) at 2,500 rpm	62.0 kW (83 hp) at 2,500 rpm	72.0 kW (97 hp) at 2,500 rpm
Gross Rated Power (ISO 14396)	54.8 kW (74 hp) at 2,500 rpm	64.0 kW (86 hp) at 2,500 rpm	74.6 kW (100 hp) at 2,500 rpm
Peak Torque	280 Nm (207 ft.-lb.) at 1,800 rpm	360 Nm (266 ft.-lb.) at 1,700 rpm	395 Nm (291 ft.-lb.) at 1,700 rpm
Displacement	3.3 L (203 cu. in.)	3.1 L (186.3 cu. in.)	3.1 L (186.3 cu. in.)
Rated Engine Speed	2,500 rpm	2,500 rpm	2,500 rpm
Torque Rise	34% at 1,800 rpm	47% at 1,700 rpm	39% at 1,700 rpm
Aspiration	Turbocharged, intercooled	Turbocharged, intercooled	Turbocharged, intercooled
Air Cleaner	Dry dual element	Dry dual element	Dry dual element
Cooling	326E / 328E / 332E		
Fan Type	Variable-speed hydraulic drive (optional reversing fan drive)		
Powertrain	326E	328E	332E
Type	Hydrostatic-manual or electro-hydraulic controls; 4 – 100 heavy-duty, continuous-loop chain	Electrohydraulic controls; 4 – 100 heavy-duty, continuous-loop chain	
Speeds			
Single Speed	10.5 km/h (6.5 mph)	11.3 km/h (7.0 mph)	11.3 km/h (7.0 mph)
2 Speed, High	16.1 km/h (10.0 mph)	19.3 km/h (12.0 mph)	19.3 km/h (12.0 mph)
System High-Pressure Relief	36 197 kPa (5,250 psi)	34 474 kPa (5,000 psi)	34 474 kPa (5,000 psi)
Axles	Induction-hardened, one-piece forged axle shafts with maintenance-free oil-bath lubrication of inner and outer axle bearings		
Maximum Axle Torque	7725 Nm (5,680 lb.-ft.)	8480 Nm (6,235 lb.-ft.)	9289 Nm (6,830 lb.-ft.)
Tractive Effort	3958 kgf (8,725 lbf)	3905 kgf (8,610 lbf)	4218 kgf (9,300 lbf)
Final Drive	High-strength, adjustment-free chains	High-strength, adjustment-free chains	High-strength, adjustment-free chains
Brakes	Spring-applied, hydraulically released, wet-disc park brake	Spring-applied, hydraulically released, wet-disc park brake	Spring-applied, hydraulically released, wet-disc park brake
Hydraulics			
Pump Flow			
Standard	80 L/m (21 gpm)	80 L/m (21 gpm)	95 L/m (25 gpm)
Total with High-Flow Option	110 L/m (29 gpm)	132 L/m (35 gpm)	144 L/m (38 gpm)
System Pressure at Couplers	23 787 kPa (3,450 psi)	23 787 kPa (3,450 psi)	23 787 kPa (3,450 psi)
Hydraulic Horsepower Flow (calculated)			
Standard	31 kW (42 hp)	31 kW (42 hp)	37 kW (50 hp)
High	47 kW (63 hp)	51 kW (68 hp)	55 kW (74 hp)
Cylinders	326E / 328E / 332E		
Type	John Deere heat-treated, chrome-plated, polished cylinder rods, hardened steel (replaceable bushings) pivot pins		
Electrical			
Voltage	12 volt		
Battery Capacity	925 CCA		
Alternator Rating	70 amp		
Lights	Halogen, 2 front and 1 rear		
Operator's Station	ROPS (ISO 3471) / FOPS (ISO 3449) structure with quick-pivot standard		
Tires/Wheels	326E	328E	332E
Standard Tire Size	12 x 16.5 10 PR Extra Wall	14 x 17.5 12 PR Extra Wall	14 x 17.5 14 PR Hauler
Serviceability			
Refill Capacity			
Fuel Tank	92 L (24 gal.)	96.5 L (25.5 gal.)	96.5 L (25.5 gal.)



Operating Weight		326E	328E	332E
Base Machine		3723 kg (8,200 lb.)	3982 kg (8,770 lb.)	4363 kg (9,610 lb.)
Machine Dimensions				
A	Length without Bucket	3.05 m (120 in.) (10 ft. 0 in.)	3.05 m (120 in.) (10 ft. 0 in.)	3.05 m (120 in.) (10 ft. 0 in.)
B	Length with Foundry Bucket	3.66 m (144 in.) (12 ft. 0 in.)	3.66 m (144 in.) (12 ft. 0 in.)	3.66 m (144 in.) (12 ft. 0 in.)
C	Width without Bucket	1.84 m (72.6 in.) (6 ft. 1 in.)	1.95 m (76.8 in.) (6 ft. 5 in.)	1.99 m (78.4 in.) (6 ft. 6 in.)
D	Height to Top of ROPS	2.12 m (83.3 in.) (6 ft. 11 in.)	2.15 m (84.8 in.) (7 ft. 1 in.)	2.15 m (84.7 in.) (7 ft. 1 in.)
E	Height to Hinge Pin	3.18 m (125.4 in.) (10 ft. 5 in.)	3.22 m (126.6 in.) (10 ft. 7 in.)	3.23 m (127.0 in.) (10 ft. 7 in.)
F	Dump Height with Foundry Bucket	2.54 m (99.9 in.) (8 ft. 4 in.)	2.57 m (101.1 in.) (8 ft. 5 in.)	2.59 m (102.0 in.) (8 ft. 6 in.)
G	Dump Reach			
	With Foundry Bucket	0.84 m (33 in.)	0.80 m (31.3 in.)	0.80 m (31.6 in.)
	With Construction Bucket	1.02 m (40.1 in.) (3 ft. 4 in.)	0.98 m (38.6 in.) (3 ft. 3 in.)	0.98 m (38.7 in.) (3 ft. 3 in.)
H	Wheelbase	1.23 m (48.3 in.) (4 ft. 0 in.)	1.23 m (48.3 in.) (4 ft. 0 in.)	1.23 m (48.3 in.) (4 ft. 0 in.)
I	Ground Clearance	0.25 m (9.7 in.)	0.29 m (11.6 in.)	0.28 m (10.8 in.)
J	Angle of Departure	26 deg.	29 deg.	29 deg.
K	Front Turn Radius with Foundry Bucket	2.17 m (85.5 in.) (7 ft. 1 in.)	2.17 m (85.3 in.) (7 ft. 1 in.)	2.17 m (85.3 in.) (7 ft. 1 in.)
L	Dump Angle (full lift height)	45 deg.	45 deg.	45 deg.
M	Bucket Rollback (ground level)	35 deg.	35 deg.	35 deg.

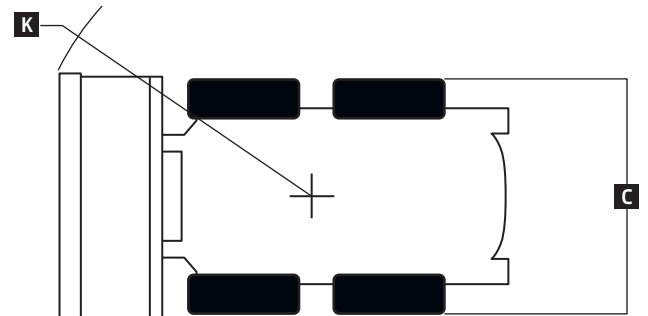
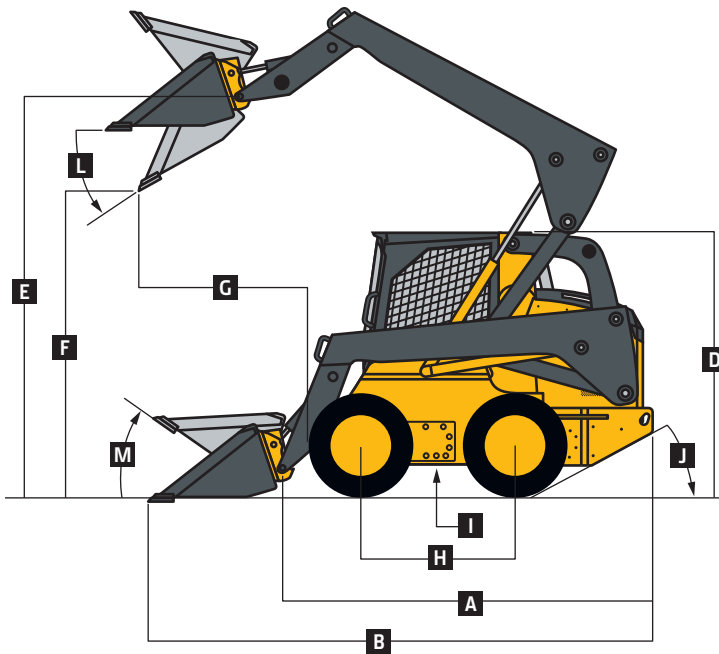

Loader Performance		326E	328E	332E
Tipping Load		2443 kg (5,380 lb.)	2542 kg (5,600 lb.)	2906 kg (6,400 lb.)*
SAE Rated Operating Capacity		1221 kg (2,690 lb.)	1271 kg (2,800 lb.)	1453 kg (3,200 lb.)
	With Counterweight	1289 kg (2,840 lb.)	1338 kg (2,950 lb.)	1521 kg (3,350 lb.)†
Boom Breakout		2270 kg (5,000 lb.)	2270 kg (5,000 lb.)	2996 kg (6,600 lb.)
Bucket Breakout Force		3519 kg (7,750 lb.)	4676 kg (10,300 lb.)	6299 kg (13,875 lb.)

*With 1 set of standard counterweights.

†With 2 sets of standard counterweights.

Additional equipment

Key: ● Standard ▲ Optional or special

See your John Deere dealer for further information.

318	320	326	328	332	Engine
●	●	●			Meets EPA Final Tier 4/EU Stage IV emissions
			●	●	Meets EPA Interim Tier 4/EU Stage IIIB emissions
●	●				Yanmar 4TNV98C
▲	▲	●			Yanmar 4TNV98CT
			●	●	Yanmar 4TNV94CHT
●	●	●	●	●	Auto-idle
▲	▲	▲	●	●	Automatic fan tensioner
●	●	●	●	●	Automatic preheat
●	●	●	●	●	Electronic injection system
●	●	●	●	●	John Deere COOL-GARD™ II Extended-Life Engine Coolant
●	●	●	●	●	John Deere Plus-50™ 10W30 initial engine oil fill*
●	●	●	●	●	5-micron primary fuel filter and water separator
▲	▲	▲	▲	▲	Cold-weather starting package
Cooling System					
●	●	●	●	●	Coolant recovery tank
●	●	●	●	●	Variable-speed hydraulically driven fan cooling system
▲	▲	▲	▲	▲	Reversing fan drive
Powertrain					
●	●	●	●	●	High-strength adjustment-free final-drive chains
●	●	●	●	●	Spring-applied hydraulically released wet-disc park brake
●	●	●	●	●	Wet-disc brakes
▲	▲	▲	▲	▲	Transmission, 2-speed
Hydraulic System					
●	●	●	●	●	John Deere hydraulic cylinders with cushioned boom cylinders
●	●	●	●	●	Connect-under-pressure auxiliary couplers
●	●	●	●	●	Quick-check hydraulic fluid-level sight glass
●	●	●	●	●	5-micron hydraulic filter
▲	▲	▲	▲	▲	High-flow hydraulics
Electrical					
●	●	●	●	●	Automatic shutdown with alarm
●	●	●	●	●	Auxiliary hydraulics operator-presence system
●	●	●	●	●	Courtesy lighting

318	320	326	328	332	Electrical (continued)
●	●	●	●	●	Deluxe instrumentation EMU with: Operator-selectable monitoring – Hour meter, engine rpm, battery voltage, diagnostics, EMU configuration, engine coolant temperature, hydraulic oil temperature / LED warning indicators – Glow plug, seat switch, seat belt, door open, auxiliary hydraulics, park brake engaged, 2-speed engaged, stop, low engine oil pressure, engine coolant over-temperature, battery not charging, air filter restriction, hydraulic filter restriction
●	●	●	●	●	Front and rear halogen work lights
●	●	●	●	●	Triple interlock operator-presence control system
▲	▲	▲	▲	▲	Backup alarm
●	●				Battery, 750 CCA
▲	▲	●	●	●	Battery, 925 CCA
▲	▲	▲	▲	▲	Hazard warning lights
▲	▲	▲	▲	▲	Strobe light, amber
▲	▲	▲	▲	▲	Horn
Operator's Station					
●	●	●	●	●	Deluxe cab headliner
▲	▲	▲	●	●	Electrohydraulic (EH) ISO-pattern joystick controls
▲	▲	▲	▲	▲	EH H-pattern joystick controls
▲	▲	▲	▲	▲	EH foot and joystick controls
▲	▲	▲	▲	▲	EH switchable foot-ISO-H-pattern controls
▲	▲	▲	▲	▲	Keyless-start sealed-switch module with integrated anti-theft system
●	●	●	●	●	Electronic push-button auxiliary controls
●	●	●	●	●	Pull-down lap bar
●	●	●	●	●	Quick-pivot ROPS
●	●	●	●	●	Rear window
●	●	●	●	●	Top window
▲	▲	▲	▲	▲	Removable top window
▲	▲	▲	▲	▲	Sliding/locking glass side windows
●	●	●	●	●	ROPS/FOPS operator structure
●	●	●	●	●	Seat belt, 51-mm (2-in.), retractable
▲	▲	▲	▲	▲	Seat belt, 76-mm (3-in.), retractable
▲	▲	▲	▲	▲	Shoulder belt
●	●	●	●	●	Water-shedding deluxe vinyl seat
▲	▲	▲	▲	▲	Deluxe vinyl suspension seat

318	320	326	328	332	Operator's Station (continued)
▲	▲	▲	▲	▲	Air-ride (cloth) seat
▲	▲	▲	▲	▲	Air-ride (vinyl) seat
●	●	●	●	●	12-volt power port / Dome light / Cargo storage / Beverage holder
▲	▲	▲	▲	▲	Air conditioning with heater/defroster
▲	▲	▲	▲	▲	Heater with defroster
▲	▲	▲	▲	▲	AM/FM/weatherband radio with auxiliary input
▲	▲	▲	▲	▲	Cab enclosure
▲	▲	▲	▲	▲	Electrohydraulic joystick controls
▲	▲	▲	▲	▲	EH joystick performance package: Switchable ISO-H pattern / Creeper mode / Boom/bucket speed settings / Adjustable propel settings / Attachment controls
▲	▲	▲	▲	▲	Floor mat
▲	▲	▲	▲	▲	Floor mat with left footrest
▲	▲	▲	▲	▲	Hand controls with foot throttle
▲	▲	▲	▲	▲	Rearview mirror
▲	▲	▲	▲	▲	Severe-duty cab door
▲	▲	▲	▲	▲	Heavy-duty rear grille
Loader					
●	●	●	●	●	Integral cab boom lock
●	●	●	●	●	Patented John Deere Quik-Tatch™ (no grease required)
▲	▲	▲	▲	▲	Power Quik-Tatch
●	●	●	●	●	Patented John Deere vertical-lift boom with superior visibility
▲	▲	▲	▲	▲	Hydraulic self-leveling on/off
▲	▲	▲	▲	▲	Ride control
Other					
●	●	●	●	●	Convenient front and rear tie-downs
●	●	●	●	●	Environmental drains for all fluid reservoirs
●	▲				10 x 16.5 8 PR SKS Extra Wall Heavy Duty
	●	▲	▲		12 x 16.5 8 PR SKS Extra Wall
		▲	●	▲	12 x 16.5 10 PR Extra Wall
			▲	●	14 x 17.5 12 PR Extra Wall
			▲	▲	14 x 17.5 14 PR Hauler
▲	▲	▲	▲	▲	Chrome exhaust stack
▲	▲	▲	▲	▲**	Modular rear-weight packages
▲	▲	▲	▲	▲	Single-point lift kit
▲	▲	▲	▲	▲	SMV sign kit
▲	▲	▲	▲	▲	Spare tire and wheel
▲	▲	▲	▲	▲	Tire options: Flotation / Solid / Heavy duty

*500-hour engine oil-change intervals when John Deere Plus-50 oil and John Deere oil filter are used.

**Standard equipped with one [1] set.



Net engine power is with standard equipment including air cleaner, exhaust system, alternator, and cooling fan, at standard conditions per SAE J1349 and DIN 6270B, using No. 2-D fuel at 35 API gravity. Gross power is without cooling fan. Specifications and design subject to change without notice. Wherever applicable, specifications are in accordance with SAE standards. Except where otherwise noted, these specifications are based on units with standard equipment, full fuel tanks, and 79-kg (175-lb.) operator.